

JASON ROBB

www.jasonrobb.com jason@jasonrobb.com 617-899-6400
75 St. Alphonsus Street Apt. 705, Boston, MA, 02120, USA

I design delightful web sites.

Recent experience

Language International (October 2008–Present)
Experience design, visual design, UI, HTML/CSS, jQuery,
Drupal. www.languageinternational.com

MyHappyPlanet (April 2008–Present)
Experience design, UI, HTML/CSS, jQuery.
www.myhappyplanet.com

Jason Robb Design (2004–Present)
Freelance UX, IxD, IA, graphic design, visual identities,
HTML/CSS templates. www.jasonrobb.com

Formally educated & autodidactic

Community College of Allegheny County
Graphic communications, Associates degree (2006), Web
designer, Certificate (2007)

I attend conferences: UPA Boston, Refresh Boston, An
Event Apart, NAPP, **and presented** at Pittsburgh Web
Design Day (April 2009)

I organize a book club: UX Book Club Boston
www.uxboston.com

I write about UI Scraps: a collection of good, bad, and
noteworthy interface designs.
<http://uiscraps.tumblr.com>

And I write about design & life: www.jasonrobb.com

Inspired & influenced by:

User Experience: Adaptive
Path, Bill Buxton, James
Kalbach, Steve Krug

Web: Dan Cederholm,
Jeffrey Zeldman, Jared
Spool, Jason Santa-Maria,
Daniel Mall

Design: Paul Rand, Robert
Bringhurst, Pentagram
Partners, Edward Tufte

References available, naturally: Brian O'Neill, Karen Ong, Tony Vespa, Jim Wells

Language International: Experience design

LIME project sketchboard



24.5 man-hours per day saved.

Problem: Student advisors (SA) waste lots of time creating invoices. Their primary tasks are to get accurate prices and create a printable invoice for prospective customers.

Goals: Build a web app that makes it easy and fast to create invoices. The system must have accurate price data so the student advisors don't have to scour through PDF brochures for course prices.

Measuring the success: SA's created 1 invoice and spent 30 minutes to create it. After launching LIME they spent 1 minute per invoice. With 7 student advisors, the company saves approximately 24.5 man-hours per day.

Language International: Experience design

Left: Prototype screenshot with notes about the nuanced interactions throughout the app.

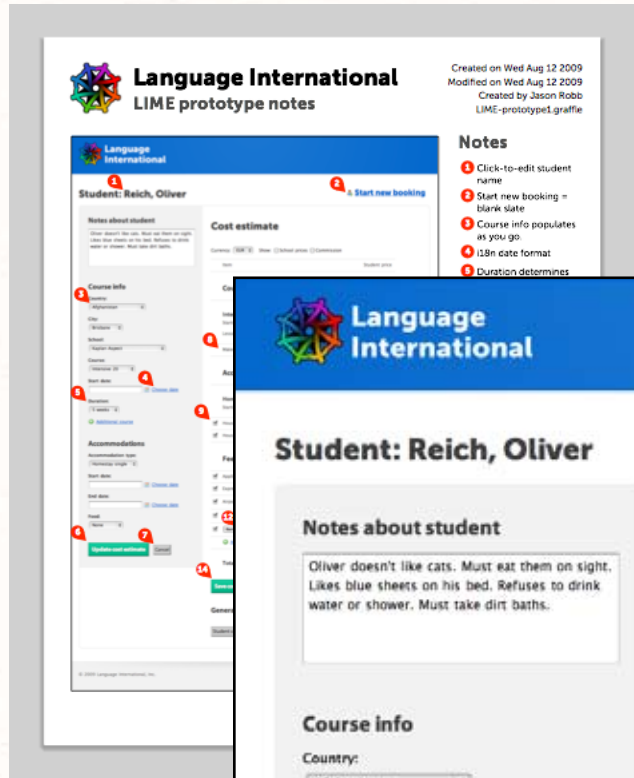

Below: Full screen view of the invoicing tool.

Language International

Student: Reich, Oliver [Start new booking](#)

Notes about student

Oliver doesn't like cats. Must eat them on sight. Likes blue sheets on his bed. Refuses to drink water or shower. Must take dirt baths.

Course info

Country: Afghanistan
City: Brisbane
School: Kaplan Aspect
Course: Intensive 20
Start date: Choose date
Duration: 5 weeks
Additional course

Accommodations

Accommodation type: Homestay single
Start date: Choose date
End date: Choose date
Food: None

Cost estimate

Currency: EUR Show: School prices Commission

Item	Student price
Intensive English Course at EAC Edinburgh, Edinburgh	€ 1,019
Starting: 20 July 2010 - 14 August 2010	
Lessons per week: 30	
Materials fee	€ 125
Homestay: Single room with Half board	€ 1,019
Starting: 19 July 2010 - 15 August 2010	
<input checked="" type="checkbox"/> Housing placement fee	€ 125
<input checked="" type="checkbox"/> Housing supplemental fee (Summer)	€ 500
<input checked="" type="checkbox"/> Application fee	€ 56
<input checked="" type="checkbox"/> Express mail (optional)	€ 125
<input checked="" type="checkbox"/> Airport transfer (one-way) (optional)	€ 62
<input checked="" type="checkbox"/> Health Insurance (1 week) (optional)	€ 61
<input checked="" type="checkbox"/> Bank transfer fee	€ 42

Total amount € 2,875

[Update cost estimate](#) [Cancel](#)

[Save cost estimate](#) [Cancel](#)

Language International: Logo design



Language International

Final logo design

Refined logo mark sketch and logo type specimens

Logo mark and type design
Scaling exercise

2008 Nov. 11
Jason Robb



Language
INTERNATIONAL
INTERNATIONAL



Language
INTERNATIONAL



Language
INTERNATIONAL



Language
INTERNATIONAL

Early sketches and ideation

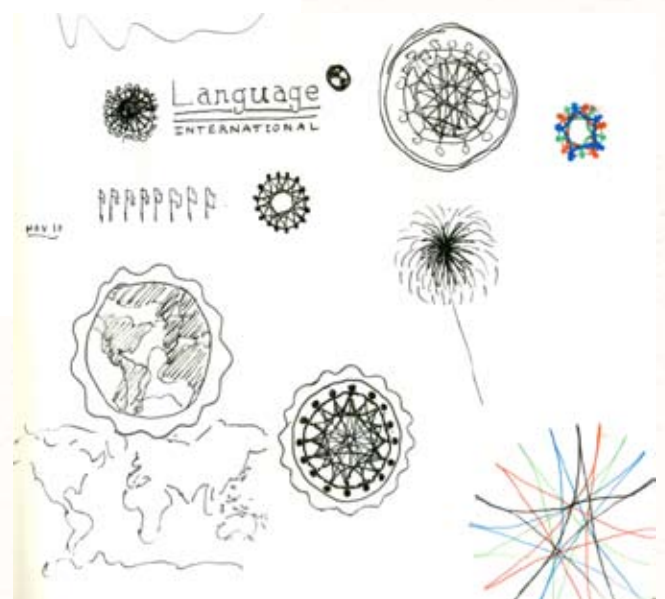

Language International: Experience design

Home page: www.languageinternational.com

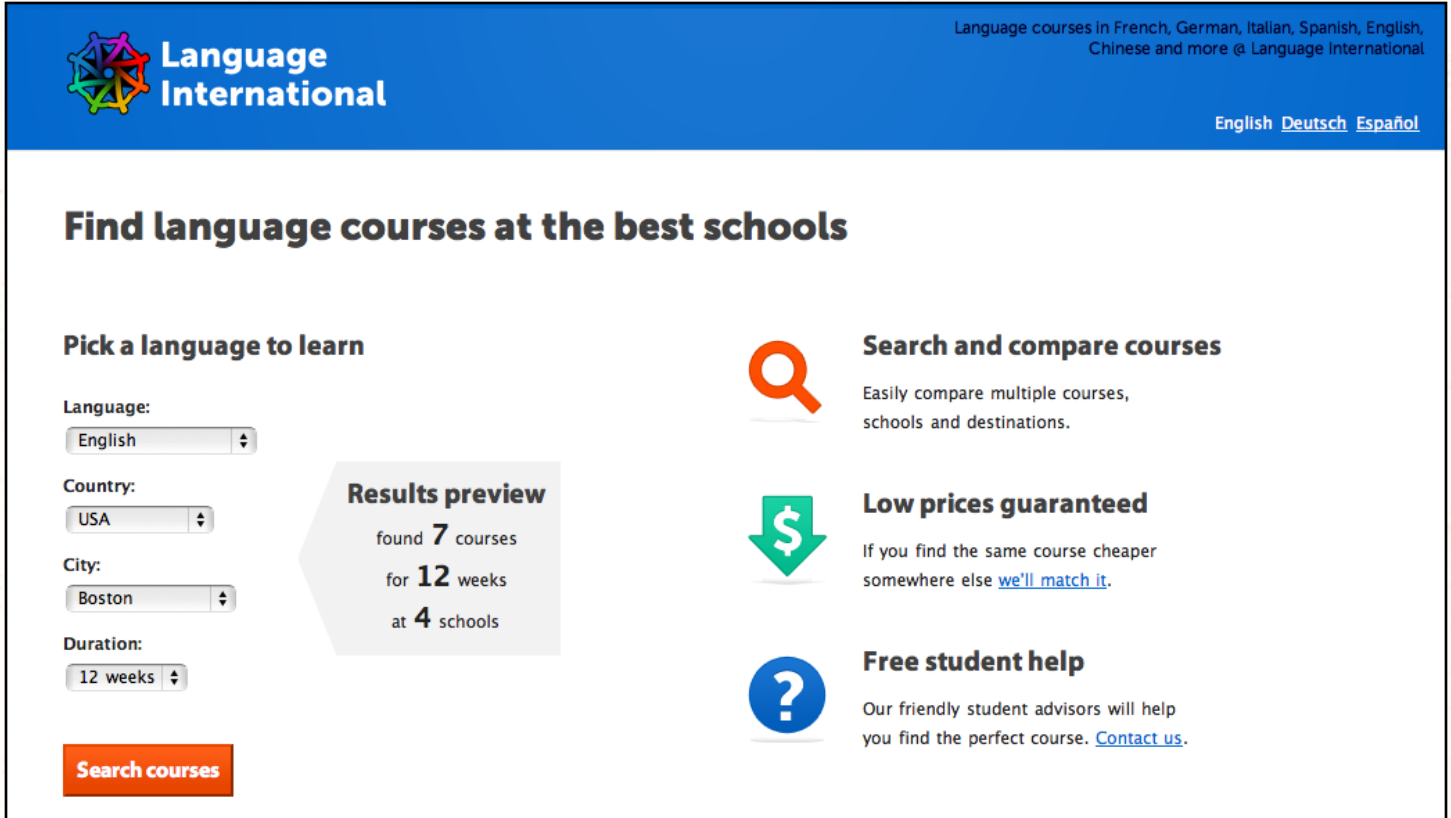

Annotated wireframe (Omnigraffle)

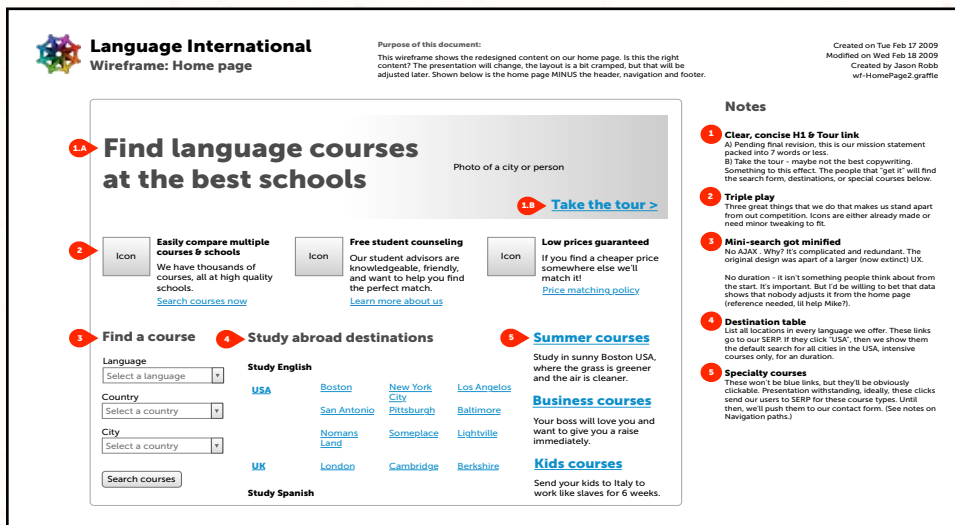

Early sketches of home page

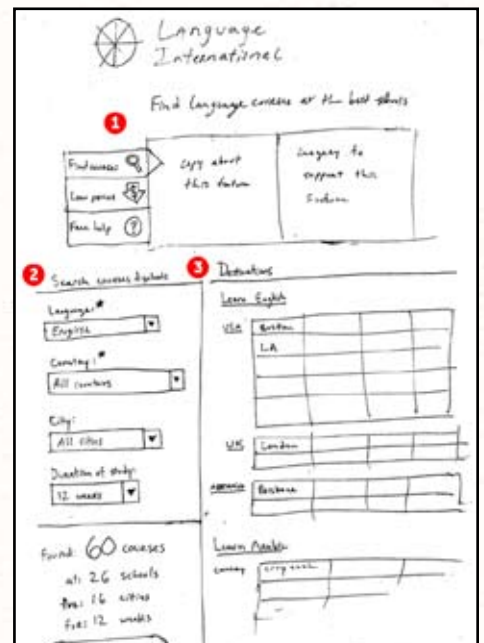

Language International: Interface design

Course detail page: www.languageinternational.com/course/758/detail

Annotated wireframe sketches

Final UI design

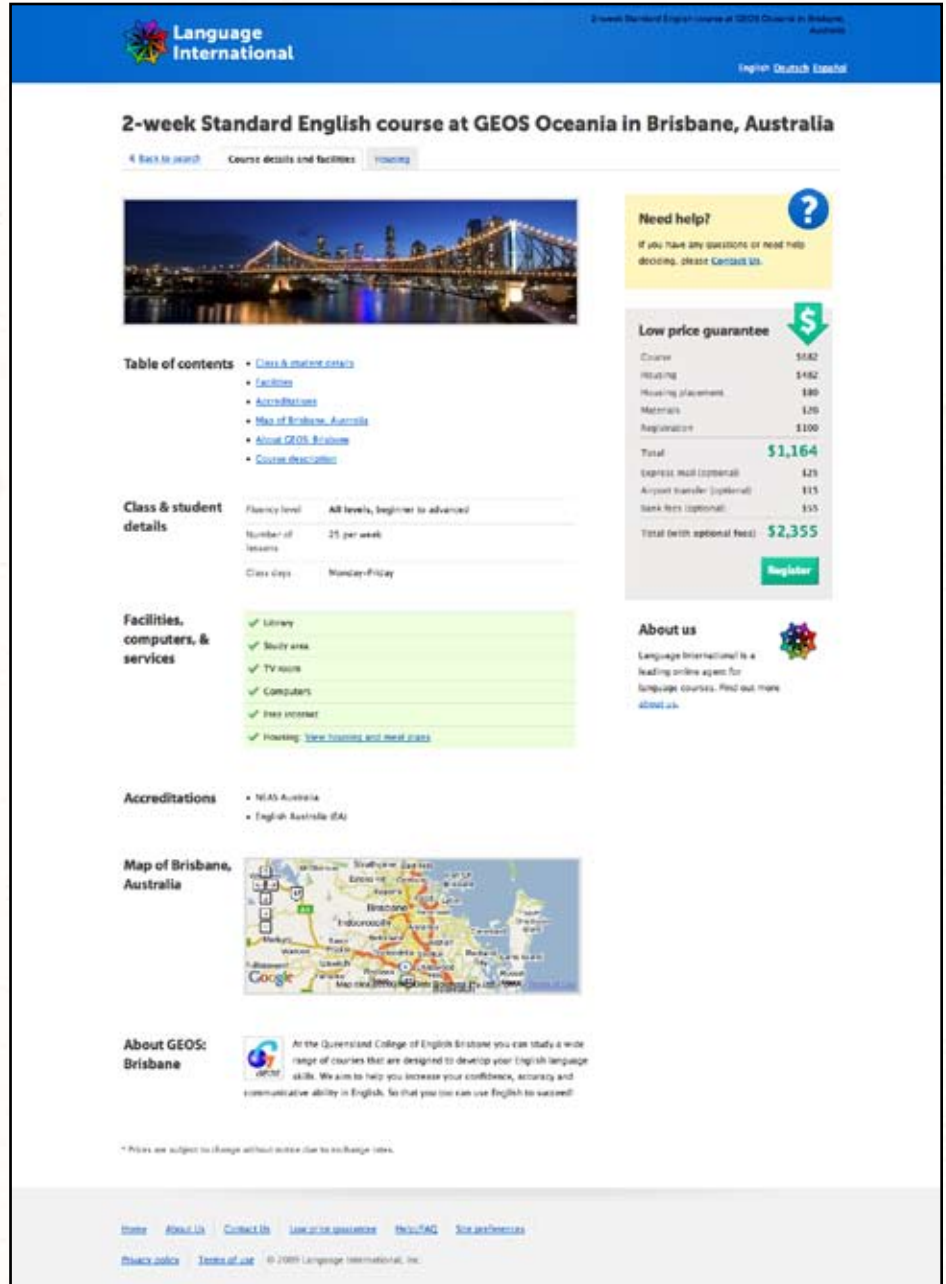

Sticky note wireframes

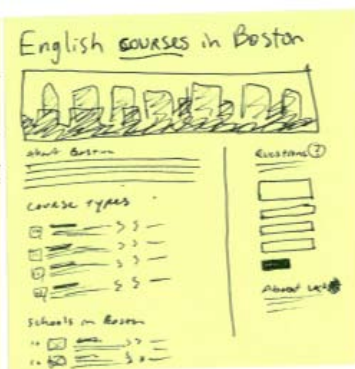

Language International: Interaction design

Showing the possible link paths to get from point A to point B

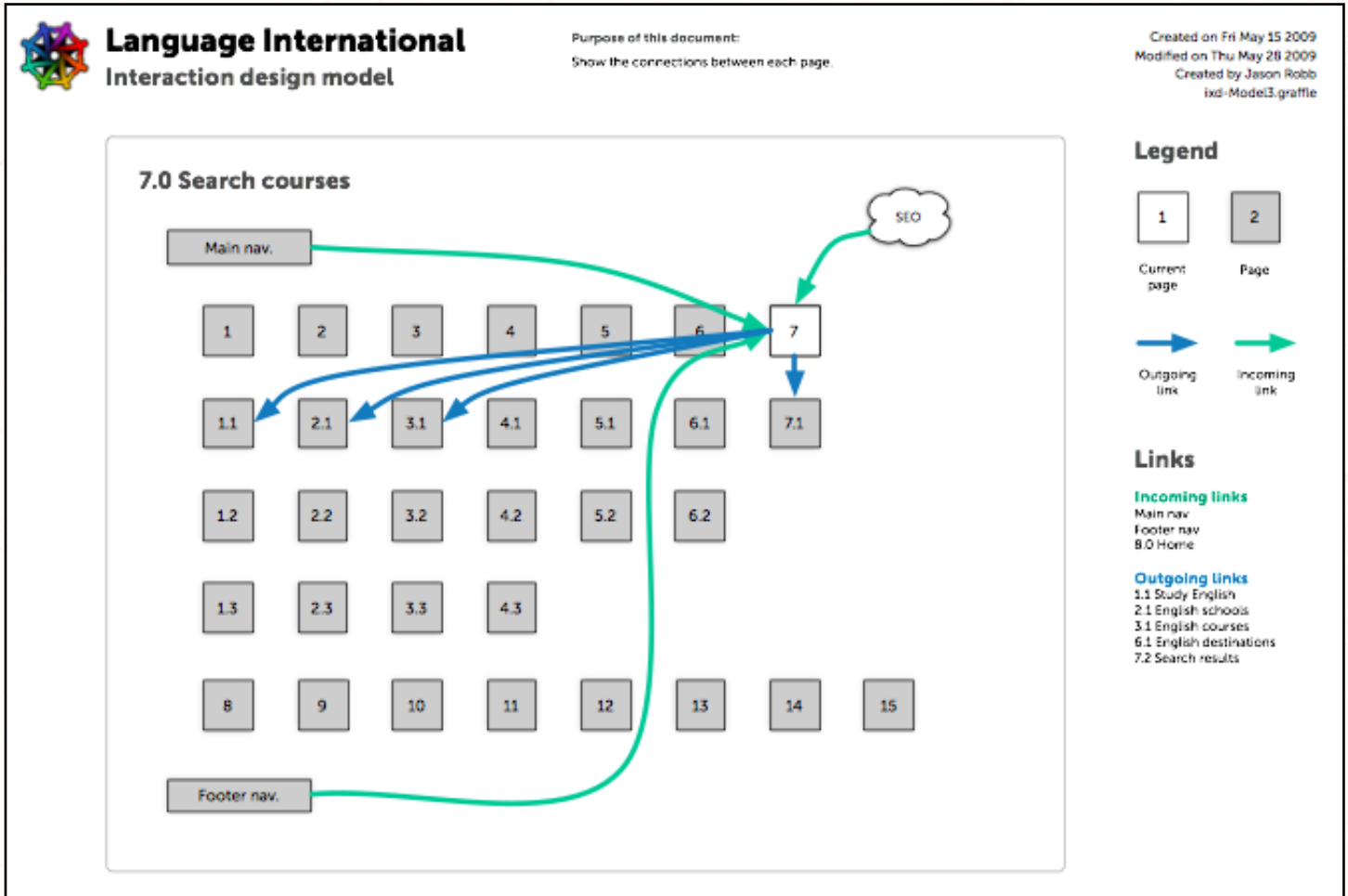

The sticky notes to the left are the early wireframes for each of the corresponding pages in the grid above.

MyHappyPlanet: Logo & Interface design



MyHappyPlanet^{BETA}
Learn a Language. Make Friends. Have Fun.

Improved logo type (globe not mine)

Redesigned, logged out home page

The screenshot shows the redesigned home page of MyHappyPlanet. At the top left is the logo featuring a globe character and the text "myhappyplanet BETA Learn a Language. Make Friends. Have Fun.". To the right are links for "Sign up free" and "Log in". Below the logo is a search bar with a "Lessons" dropdown and a "Search" button. The main content area is split into two columns. The left column has a heading "Learn a language from native speakers around the world for free." followed by "Get started: find a language partner". Below this are two dropdown menus: "I speak" and "Find fluent speakers of", both with "--Choose--" as the selected option. A green "Search" button is positioned below the second dropdown. Further down, it states "MyHappyPlanet is the home for people learning languages:" and lists three bullet points: "Send and receive messages with native speakers around the world.", "Learn about cultures and languages through lessons created by our members.", and "Watch videos uploaded by our members in multiple languages." At the bottom of this section is a blue "Sign up free" button. The right column is titled "Members online now" and lists four members with their profile pictures and details: "Soup42 speaks English and is learning Turkish.", "MyHte600 speaks English and is learning Japanese. Online in Canada.", "reneemetal speaks Spanish and is learning English. Online in Santiago, Chile", and "adnaz speaks Turkish and is learning Italian. Online in Turkey". The footer contains a row of links: "About Us", "Blog", "Contact Us", "Feedback", "Privacy Policy", "Terms of Use", and "Help". On the far right of the footer are social media icons for Facebook, Twitter, and YouTube, along with the text "© 2008 My Happy Planet, Inc. (Version: Athens)".

MyHappyPlanet: Refactoring project

Refactoring of table-based, convoluted web site. Front-end and back-end code needed to be salvaged if possible, or created anew if not. I converted countless table-based pages to CSS-based layouts.

Visual inventory of all pages



Timeline of tasks

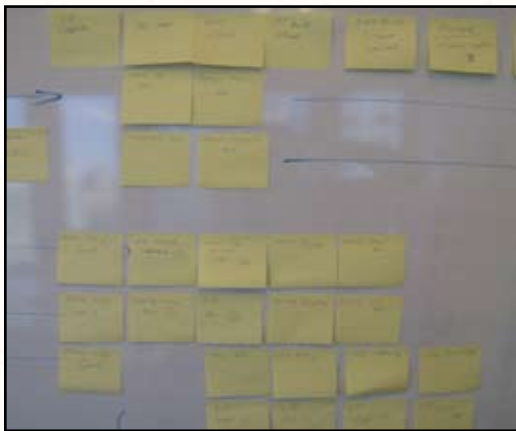

CSS file structure and outline

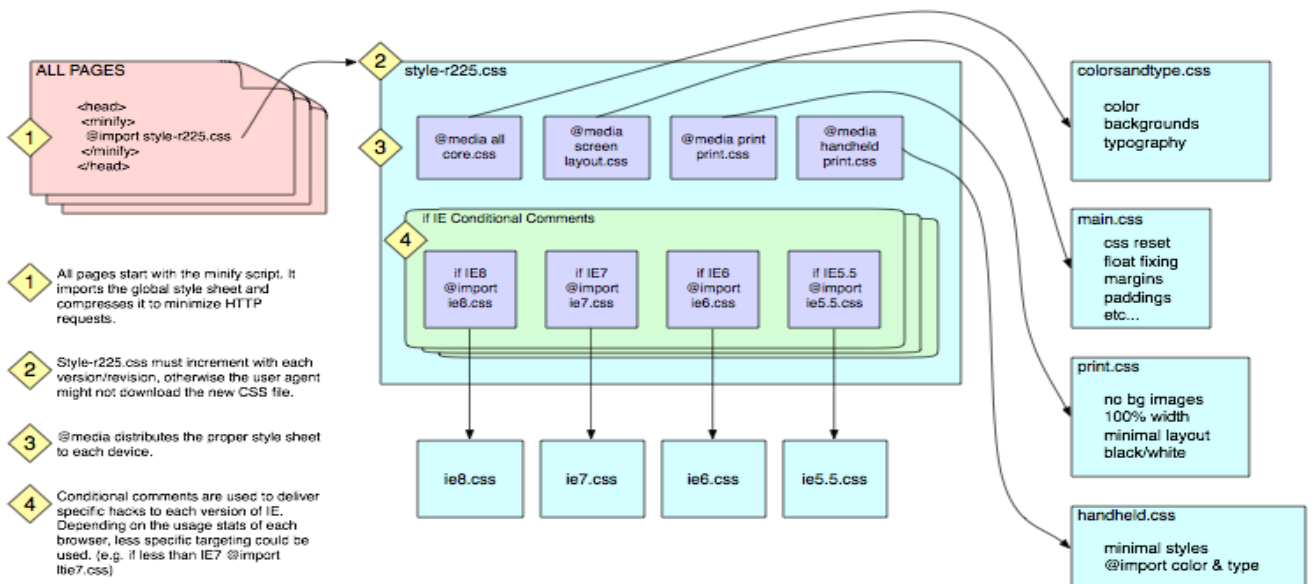

MyHappyPlanet: Interface design

Logged in home page redesign



MyHappyPlanet BETA
Learn a language. Make Friends. Have Fun.

[Edit my profile](#) [Invite friends](#) [Log out jasonrobb](#)

My home Friends (14) Videos Lessons Messages (3)

[View my profile](#) [Edit my profile](#) [My languages](#) [My contact info](#) [My pictures](#) [Preferences/email options](#)

[Immersion Active](#)
Engage boomers and seniors online. Download preview of our new book. [www.dotboombook.com](#)

[Learn like a Spy](#)
World's leading language method. Same course used by FBI & CIA. [PimpleurApproach.com](#)

[Intelligence Degree](#)
Study languages 100% online & earn a college degree. Learn how. [www.apus.edu](#)

Ads by Google

Ahoj, Jason! Time to learn Slovak!

You've got alerts:



- 3 messages from [DanaTara](#), [Natali85](#) and [lovelygirl1985](#)
- 1 profile comment was left for you on your profile page
- 14 people want to be your friend ([pinkymouse89](#), [levon870626](#) and [PinkPrincess](#))
- You may want to [edit/expand](#) your lesson "This is a great way to do stuff!", which has not been viewed by anyone in more than 2 weeks. [Manage my lessons \(1\)...](#)

Slovak conversations, partners and lessons

People like [Zeny09](#) want to practice English. [Create a lesson](#) or [help these members with their English](#).

Slovak learning partners

Find:

 revizorka , 19 Slovak	 danielMHP , 26 Slovak	 Ewellin , 20 Slovak	<input type="button" value="View barborka915's profile"/> barborka915 , 15 Slovak
---	---	---	---

Want to improve your Slovak skills fast?

[Find Slovak courses](#) at the best schools abroad



My profile (100% complete)



- [Edit my profile](#)
- [View my profile](#)
- [Add/remove photos](#)

Lessons & videos I added

- 87 lifetime views for your 2 addition(s)
- [Edit/delete my videos \(1\)](#) [add new...](#)
- [Edit/delete my lessons \(1\)](#) [add new...](#)





Chinese Learning
All Levels Free Trial Now!
Your name:
E-mail:
Country:
Tel:

1-on-1 Live Online Chinese Lessons
Specialized in Teaching Survival Chinese

[About Us](#) [Blog](#) [Contact Us](#) [Feedback](#) [Privacy Policy](#) [Terms of Use](#) [Help](#)

© 2009 My Happy Planet, Inc.



 [ElyMoore](#) has sent you a chat invitation.

 [Friends list](#) [Chat \(37\)](#)

MyHappyPlanet: Interface design

Compose message page

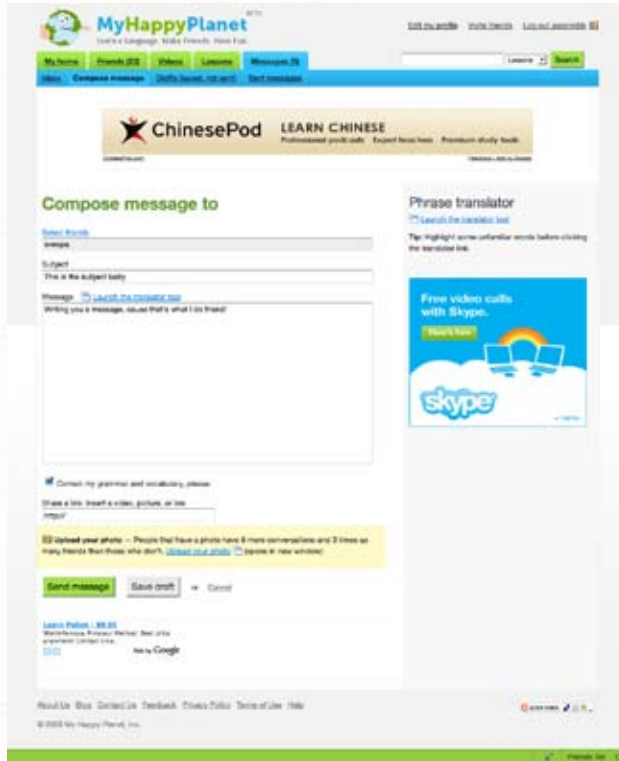

Compose message page wireframe sketch

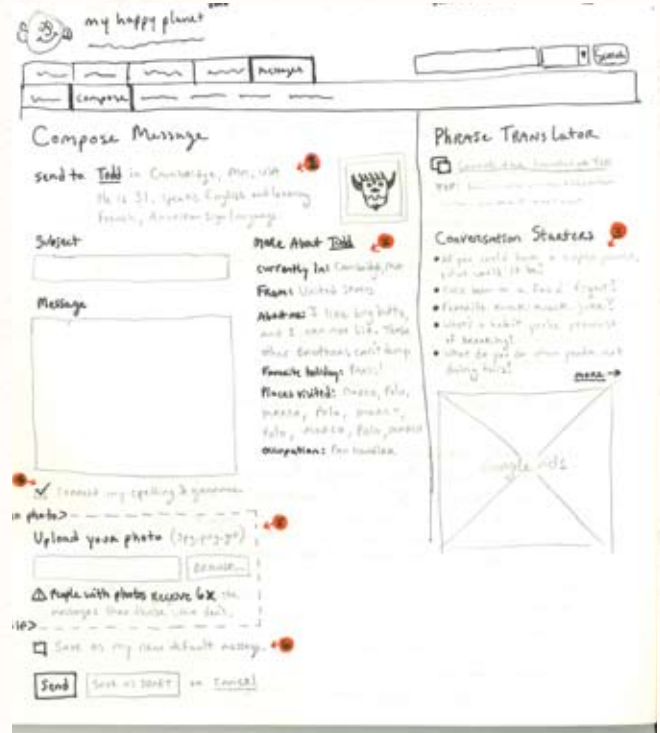

Notes on problematic UX, and considering possible solutions.

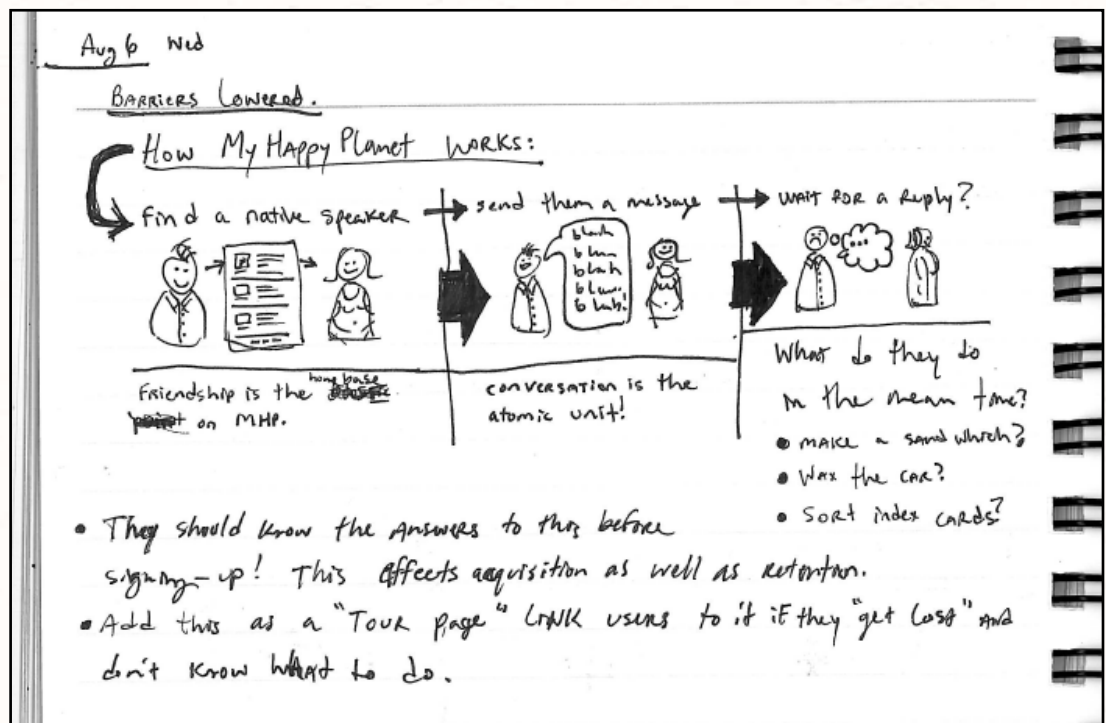

Barbara Wells Studio: Art direction

Home page: www.barbarawellsstudio.com



I designed & developed the whole site from front to back, and continue to maintain the site for the Wells.

Collections page:
www.barbarawellsstudio.com/collections/

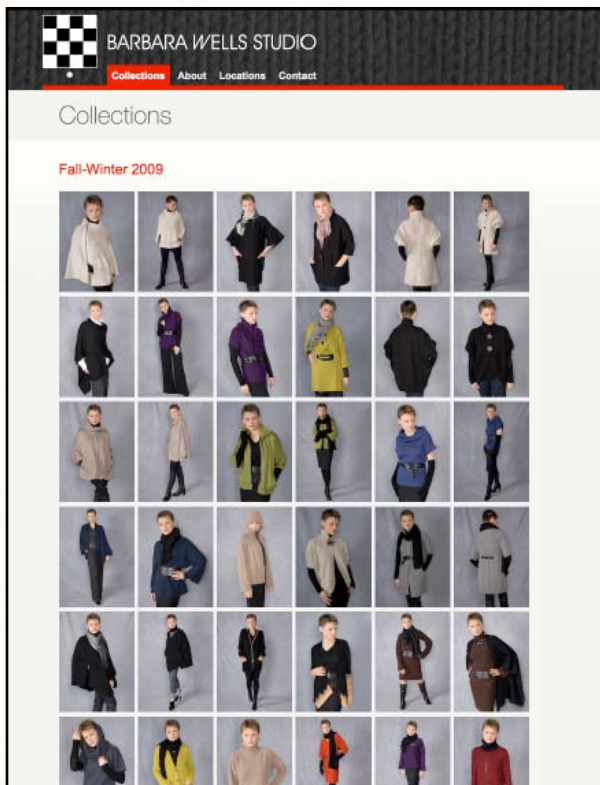

About page:
www.barbarawellsstudio.com/about/



Barbara Wells Studio: Art direction

Locations page: www.barbarawellsstudio.com/locations/

BARBARA WELLS STUDIO

Collections
About
Locations
Contact

Locations

Retail

Although Barbara Wells Studio only sells direct to qualified buyers on a wholesale basis, we are always happy to refer consumers to one of the fine boutiques that carry our line; see the [Contact page](#) of this web site, call, or fax us a note. In addition, there are a number of special trunk shows held every year. Barbara attends many to meet everyone and assist with any special ordering needs. Check the "Trunk Shows" section of this web page for the latest schedule.

Also, sign up for our email list and receive a courtesy email whenever the the latest styles are posted on the web site. (Several times per year.)

Wholesale

Barbara Wells Studio is part of [Atelier](#), a group of inspired American designers who create unusual and unique clothing, accessories, and jewelry. Please plan to join us in New York in September 2009, when we'll be showcasing our new knitwear collections for Spring-Summer 2010. We will also offer select Fall-Winter 2009 collections for immediate delivery. [Contact us](#) or [Atelier](#) for registration materials and admission requirements.

We are currently accepting orders for Fall-Winter 2009. In addition, some Spring-Summer 2009 styles are still available. Please [contact us](#) for line sheets, order forms, and additional information.

Trunk Shows

Barbara attends a series of retail trunk shows every year. They are wonderful opportunities for you to see the entire line. Barbara attends many to help with personal selections, and truly enjoys meeting everyone.

START	END	SHOW
APR	APR	Hedy Shepard
2	3	(609) 921-0582 PRINCETON, NJ 08540
MAY	MAY	Tallulah
29	30	(516) 367-4545 WOODBURY, NY 11797
JUN	JUN	Acorns
12	14	(828) 787-1877 HIGHLANDS, NC 28741
JUN	JUN	Choices
24	25	(412) 476-7600 PITTSBURGH, PA 15232
JUL	JUL	She She Chic Clothing
16	17	(918) 747-5254 TULSA, OK 74105
AUG	AUG	JV & Company
4	6	(612) 341-2094 MINNEAPOLIS, MN 55402
AUG	AUG	Anything Goes
9	10	(302) 277-2960 REHOBOTH BEACH, DE
AUG	AUG	Over The Top
13	15	(847) 433-3150 HIGHLAND PARK, IL 60035

↑ Top of Page
🏠 Home
📄 Site Info
👤 Designed by JR
Copyright © 2007 – 2009 Barbara Wells Studio. All Rights Reserved.

UI Scraps: Identity design & blog

I write about good, bad, and noteworthy interface designs:

<http://uiscraps.tumblr.com/>

UI Scraps Edit X Delete

May 14



Spaces shows where you've been, too

Mac OS X does it, wowing me with subtlety. As I'm changing spaces (multiple desktop feature on Mac OS X) an icon briefly appears on screen. It shows a big white spot [current desktop] and a white arrow [previously selected desktop].

If you switch from 4 to 3, it'll say so. This is great, because they could have overlooked it and just showed the current desktop with a white block. But showing where you came from is also important if you want to get back there. Lovely.

No comments yet

Tags: [good](#) [Mac OS X](#) [spaces](#) [icon](#) [desktops](#)

[Community Page](#) [Comments feed](#)

Add New Comment

Logged in as [jasonrobb](#)
[Logout from Disqus](#)

Type your comment here.

[Post as jasonrobb](#)

Trackbacks

[\(Trackback URL\)](#)

blog comments powered by [DISQUS](#)

Copyright © 2008–2009 UI Scraps—a Jason Robb project.
[Post archive](#)

About UI Scraps

UI Scraps is a collection of good, bad and noteworthy user interface designs found by [Jason Robb](#)

Subscribe & share

Enter email address

[RSS feed](#) [Twitter](#)

[SHARE](#) [Facebook](#) [LinkedIn](#) [Google+](#)

Top tags

[good](#) [bad](#) [Mac OS X](#)
[form](#) [call to action](#)
[navigation](#) [usable links](#)
[search icon](#) [preview](#) [login](#)
[copywriting](#) [checkout](#) [Facebook](#)
[placement](#) [pagination](#) [annoying](#)
[submit](#) [blog](#) [button](#) [warning](#)
[buttons](#) [Windows](#) [hover](#) [UX](#) [product](#)
[Flickr](#) [software](#) [time tracking](#)
[versions](#) [flowmaps](#) [Gridiron](#) [Flow](#)
[pop up](#) [process](#) [progress](#) [color](#)
[metaphor](#) [input](#) [Google](#)

Send feedback

Send your suggestions, questions or UI scraps to me, I'd love to hear from you.

Thanks for visiting!

Away

UX Boston book club: web site

I organize a book club for people interested in User Experience design. This site provides some basic info about the club and links to popular UX books. <http://uxboston.com>



Boston Book Club

A book club for people interested in User Experience

An offshoot of, and inspired by the [UX Book Club](#)

Schedule

Last meeting: "Don't Make Me Read" (get it?)
Wednesday, May 6th, 2009 @7PM



UX Boston Book Club

A book club for people interested in User Experience
an offshoot of and inspired by the UX Book Club

Schedule

Last meeting: "Don't Make Me Read" (get it?)
Wednesday, May 6th, 2009 @7PM

if you can't, TE and I'll be there, too!

Starting off the evening with some food and an introduction to the site is looking forward to meeting you! Don't miss it!

Book: Don't Make Me Read



RSVP please!

Save a seat in 15-20 minutes on [Google Maps](#) or [MapQuest](#)

Venue















Address:
Cambridge, MA 02142
United States

Map: [Google](#), [Yahoo!](#)



Books

Here's a list of all our past readings:

 Don't Make Me Read by Steve Krug	 Don't Make Me Think by Steve Krug	 The Elements of User Experience by Jesse James Garrett
 The Elements of User Experience by Jesse James Garrett	 Don't Make Me Think by Steve Krug	 The Elements of User Experience by Jesse James Garrett
 Don't Make Me Read by Steve Krug	 Don't Make Me Think by Steve Krug	 The Elements of User Experience by Jesse James Garrett
 Don't Make Me Read by Steve Krug	 Don't Make Me Think by Steve Krug	 The Elements of User Experience by Jesse James Garrett
 Don't Make Me Read by Steve Krug	 Don't Make Me Think by Steve Krug	 The Elements of User Experience by Jesse James Garrett
 Don't Make Me Read by Steve Krug	 Don't Make Me Think by Steve Krug	 The Elements of User Experience by Jesse James Garrett

Don't miss a good read! Get involved by [filling out the survey](#)!

Keep in touch

Subscribe and receive the UX Book Club Bulletin

- [RSS](#)
- [Facebook](#)
- [Twitter](#)
- [LinkedIn](#)
- [Google+](#)
- [The UX Book Club Website](#)

What's the UX Book Club?

Here's the survey for the UX Book Club and the survey for the UX Book Club.

Survey

If you want to receive more info, please fill out the survey.

Survey

What is your name?
1.

How often do you read books?
2. Never
3. Sometimes
4. Often
5. Always

What is your profession?
6.

What is your favorite book?
7.

What is your favorite author?
8.

What is your favorite genre?
9.

What is your favorite book club?
10.

What is your favorite book club?
11.

What is your favorite book club?
12.



How'd I do?

**Let's get in touch,
we've got work to do.**

www.jasonrobb.com

jason@jasonrobb.com

617-899-6400

75 St. Alphonsus Street

Apartment 705

Boston, MA, 02120 USA

**Whether you loved it or
hated it, thanks for your time!**